



## Genetic Linkage Map of Oriental × Oriental Lily Population via AFLP and SSR Markers

Alireza Noroozisharaf<sup>1\*</sup>, Younes Pourbeyrami Hir<sup>2,3</sup>, Ming Jun<sup>3\*</sup>

1 Department of Horticultural Science, Faculty of Agriculture, Bu-Ali Sina University, Hamedan, Iran

2 Department of Horticulture, Faculty of Agriculture and Natural Resources, Mohaghegh Ardabili University, Ardabil, Iran

3 Institute of Vegetables and Flowers, Chinese Academy of Agricultural Sciences, Beijing 100081, China

### ARTICLE INFO

#### Article history:

Received: 28 January 2024,

Received in revised form: 27 April 2024,

Accepted: 1 June 2024

#### Article type:

Research paper

#### Keywords:

Linkage Group,

Loci,

Map,

Maternal,

Paternal

#### COPYRIGHT

© 2025 The author(s). This is an open-access article distributed under the terms of the Creative Commons Attribution License (CC BY). The use, distribution or reproduction in other medium is permitted, provided the original author(s) and source are cited, in accordance with accepted academic practice. No permission is required from the authors or the publishers.

### ABSTRACT

Linkage maps are the framework for using genetic markers in biotechnological programs. In this experiment, two widely used markers were applied to find the loci of some momentous ornamental traits in lily flowers. A mapping population of 100 F<sub>1</sub> progeny was used to construct the genetic linkage maps using the CP (out breeder full-sib family) model of JoinMap4 software. A total of 940 primers were tested, and the best ones were 172 primer pairs, including 96 AFLP markers and 76 SSR markers used for map construction. A total of 616 loci were scored, with 465 loci for the AFLP marker and 151 for the SSR marker. The whole mapped length was 2144.2 cM. The overall number of mapped loci was 189 loci, of which 152 loci were assessed by AFLP markers and 47 by SSR markers. The full length of linkage groups for the maternal map was 861.6 cM with 12 linkage groups. The shortest and longest linkage group gaps in the maternal maps was 2.2 cM and 55.7 cM, respectively. The number of mapped loci in maternal genetic linkage maps was 52 loci, consisting of 42 for the AFLP markers and 10 for the SSR markers. In paternal maps, the mapped loci were 51, and the linkage group's entire length was 676 cM. The shortest linkage group gap for the paternal map was 0.1 cM, while the longest gap was 47.7 cM. In integrated plants, 6 linkage groups were found with 86 completely assessed loci. The total length of the linkage group for integrated maps was 606.6 cM. The shortest and longest gap of LGs was 0.2 cM and 26.8 cm, respectively.

### Introduction

Lily, a perennial bulbous ornamental plant belonging to the subclass monocotyledon and the family Liliaceae, comprises nearly 100 species distributed across the Northern Hemisphere, extending into the Asian tropics (Van Tuyl et al., 2011). DNA-based markers, whether PCR-based

or non-PCR-based, have been widely utilized in various fields such as genetic engineering, embryology, physiology, and taxonomy. These markers are instrumental in elucidating the genetic structure of plant species and are effective in the identification of species and cultivars, which is crucial for correcting misidentifications

\*Corresponding author's email: [a.noroozi@basu.ac.ir](mailto:a.noroozi@basu.ac.ir), [mingjun@caas.cn](mailto:mingjun@caas.cn)

in local markets. Several markers, including random amplified polymorphic DNA (RAPD), restriction fragment length polymorphism (RFLP), inter-simple sequence repeat (ISSR), amplified fragment length polymorphism (AFLP), simple sequence repeat (SSR), and single nucleotide polymorphism (SNP), have been employed to develop genetic linkage maps and assess genetic diversity in plant genomes (Kiran et al., 2010). Among these, AFLP and SSR markers, both PCR-based techniques, are extensively used for genome mapping, genetic fingerprinting, and studies of genetic variability in ornamental plants and crops such as lily (Shahin et al., 2011; Tokgöz et al., 2024; Van Heusden et al., 2001), wintersweet (*Chimonanthus praecox* L. Link) (Chen and Chen, 2010), iris (Tang et al., 2009), carnation (Yagi et al., 2013), rose (Hibrand-Saint Oyant et al., 2008), walnut (Nickravesh et al., 2023), Iranian melon (Danesh et al., 2015), soybean (Morgante et al., 1994), chickpea (Nayak et al., 2010; Winter et al., 1999), and jute (Das et al., 2012).

The primary breeding groups of lilies are: 1) *Longiflorum* hybrids (L genome), 2) Asiatic hybrids (A genome), and 3) Oriental hybrids (O genome). Oriental lilies, characterized by their large, fragrant flowers, represent one of the three main groups of lilies in the ornamental market. Identifying the loci that control key ornamental traits in this group through genetic mapping is of significant value, as it may facilitate the cloning of genes responsible for these important traits. The QTL positions of several significant ornamental traits in the OO (Oriental × Oriental) lily population were reported in a recent study by Pourbeyrami-Hir et al. (2019). However, to date, no genetic linkage map for OO lilies has been reported. Thus, this experiment was conducted to develop the first genetic linkage map of an F1 population using AFLP and SSR markers, providing a framework for future studies.

## Material and Methods

### *Plant materials*

This research was conducted at the Institute of Vegetables and Flowers, Chinese Academy of Agricultural Sciences. The plants were cultivated in a greenhouse located in Yunnan Province, a renowned habitat for *Lilium* species in China. Two Oriental lily cultivars were selected for the study. The first cultivar, *Lilium* 'Sorbonne,' was used as the mother plant and is characterized by its striking flowers with darker pink spots on the petals. The second cultivar, *Lilium* 'Gaudi,' known for its large white flowers, some varieties of which display light yellow mid-veins without any spots

on the petals, was used as the donor plant. Following flowering, fertilization was carried out by transferring pollen from *Lilium* 'Gaudi' to *Lilium* 'Sorbonne.' The resulting OO crosses in lilies were successful, producing 261 individuals.

The seeds were harvested in October and subsequently dried. After drying, the seeds were soaked to absorb water, becoming saturated by December. A cold stratification treatment at 4 °C was then applied to facilitate seed germination. To achieve this, the seeds were mixed with peat and stored at the specified temperature until germination. By March, the seeds began to germinate and were then sown in the greenhouse. The plants were labeled sequentially, with numbers ranging from 1 to 261.

### *Genomic DNA isolation*

To extract high quality DNA, five young leaves were harvested from each individual. The CTAB (1 M Tris-HCl (pH = 7.5) 20 mL, NaCl 16.364 g, and 0.5 M EDTA (pH = 8.0) 8 mL, CTAB 4 g ddH<sub>2</sub>O up to 200 mL) method was used for genomic DNA extraction.

### *SSR marker methodology*

A total of 306 SSR primers (Hibrand-Saint Oyant et al., 2008; Nakatsuka et al., 2012; Yuan et al., 2013) were selected for preliminary testing on 12 plants, which included the two parent plants and ten progenies. The most effective primers were subsequently chosen for testing the entire population. PCR was performed in a 20 µL reaction mixture containing 10 µL of PCR master mix 3 (comprising 100 mM KCl, 20 mM Tris-HCl, pH 8.0, 0.1 mM EDTA, 1 mM DTT, stabilizer, and 50% glycerol), 0.6 µL of each forward and reverse primer, 40 ng (2 µL) of DNA template, and 6.8 µL of ddH<sub>2</sub>O. The PCR protocol was as follows: an initial denaturation at 94 °C for 5 minutes, followed by 40 cycles of denaturation at 94 °C for 30 seconds, annealing at primer-specific temperatures for 30 seconds, extension at 72 °C for 1 minute, and a final extension at 72 °C for 7 minutes. The amplified products were subjected to electrophoresis in a 6% denaturing polyacrylamide gel using a conventional PAGE system for 90 minutes. DNA fragments were separated by PAGE and visualized using silver staining methods (Promega, USA).

### *Slab gel preparing and staining*

A total volume of 30 mL gel (40% Acr-Bis (19:1) 6.0 mL, ddH<sub>2</sub>O 21 mL, 10xTBE 3.0 mL, 10% APS 250 µL, TEMED 30 µL) was used to pour between glasses to prepare slab gel. The following steps

were performed for staining the gels: 1) Separating the gel from the glasses, 2) fixing the gel bands in a mixture of 50 mL of absolute ethanol, 3) 2.5 mL of acetic acid and 450 mL of ddH<sub>2</sub>O for 6 min, 4) performing silver staining using 500 mL ddH<sub>2</sub>O and 1 g of silver nitrate for 12 min, 5) removing the silver nitrate using 500 mL ddH<sub>2</sub>O for 25 s followed by immersing the gels in 500 mL of ddH<sub>2</sub>O + 120 µL of sodium sulfite for 25 s, 6) staining the gel using 500 mL ddH<sub>2</sub>O + 7.5 g of sodium hydroxide and + 1.5 mL formaldehyde for 8 min, 7) placing the gels in the first step solution for a few seconds and then preparing them for analysis by photography.

### ***AFLP marker methodology***

This marker methodology consisted of 3 steps: 1) Digestion and ligation, 2) Pre-amplification, and 3) Selective amplification (Vos et al., 1995).

### ***Digestion and ligation***

For digestion and ligation of DNA, all materials [DNA 500 ng, EcoRI buffer 2 µL, ATP (100 mM) 0.04 µL, 100×BSA (10 mg mL<sup>-1</sup>) 0.1 µL, EcoRI adapter (5 pM) 0.4 µL, MseI adapter (50 pM) 0.4 µL, EcoRI (20 U µL<sup>-1</sup>) 0.12 µL, MseI (10 U µL<sup>-1</sup>) 0.24 µL, T4 DNA Ligase (3 U µL<sup>-1</sup>) 0.33 µL, ddH<sub>2</sub>O up to 20 µL] were mixed and put in PCR machine at 37 °C for 14 h (overnight) and then 65 °C for 20 min. The tubes were picked up and placed on ice for fast cooling for at least 2 min.

### ***Pre-amplification***

The pre-amplification protocol was conducted as a total volume of 20 µL [digestion and ligation product 5 µL, *E00* 0.8 µL, *M00* 0.8 µL, 5×Go *Taq* buffer 4 µL, dNTPs (10 mM) 0.4 µL, GoTaq (5 U µL<sup>-1</sup>) 0.2 µL, ddH<sub>2</sub>O 8.8 µL]. The PCR reaction was performed as: 94 °C for 3 min followed by 30 cycles of 94 °C for 30 s, 56 °C for 30 s and 72 °C for 1 min, final 72 °C for 7 min for elongation and kept at 4 °C forever.

### ***Selective amplification***

The pre-amplification products were diluted 5 times and used in the selective amplification step. This reaction contains 5 µL of diluted pre-amplification product mixed with 1 µL of each E-NNN and M-NNN primers then 0.4 µL of dNTPs (10 mM), 4 µL of 5×Go *Taq* buffer and 0.2 µL of Go *Taqase* (5 U µL<sup>-1</sup>) were added. Finally, the total volume was adjusted in 20 µL with ddH<sub>2</sub>O. Touch down PCR was used as: 94 °C for 3 min followed by 12 cycle of 94 °C for 30 s, 65 °C (-0.7 °C cycle<sup>-1</sup>) for 30 s and 72 °C for 1 min then 25 cycles of 94 °C for 30 s, 56 °C for 30 s and 72 °C for 1 min, final 72 °C for 7 min for elongation and kept at 4 °C

forever.

### ***Polyacrylamide gel preparing and staining***

A solution of 5% polyacrylamide gel was prepared, and then pre-electrophoresis was conducted at 65W for 30 min. After loading the PCR product, a final electrophoresis was performed for 90 min. Two boards were separated from each other, and staining of the gels was carried out as following steps: 1) band fixation: 200 mL absolute ethanol + 10 mL acetic acid + 2000 mL ddH<sub>2</sub>O for 6-7 min, 2) silver staining: 2000 mL ddH<sub>2</sub>O + 3 g silver nitrate and 3 mL formaldehyde for 15 min, 3) silver nitrate was removed using 2000 mL ddH<sub>2</sub>O for 3-4 s, 4) developing step: 2000 mL ddH<sub>2</sub>O + 30 g sodium hydroxide + 3 mL formaldehyde for 10-12 min, 5) using fixative solution for 2 min and then washing.

### ***Linkage mapping procedure***

The linkage groups (LGs) were constructed using JOINMAP 4.0 software, applying the CP (cross pollinators, outbreeder full-sib family) model to treat segregation markers. Genetic linkage maps were developed for Liliium 'Gaudi' (paternal maps), Liliium 'Sorbonne' (maternal maps), and the F1 progeny (integrated maps). An independence LOD (Log of Odds) score ranging from 2 to 10 was used to generate the maps. The smallest and largest gaps between markers were measured in centiMorgans (cM). The mapping algorithm employed was regression mapping, utilizing Haldane's mapping function.

## **Results**

### ***SSR primers results***

In this study, a total of 306 SSR primers were initially tested on the parent plants and on ten F1 progeny. Of these, 76 primers that produced clear and distinct bands were selected for further testing across the entire F1 population (Table 1, Figs. S1 and S2). These selected primers generated 151 distinct loci, along with several faint and unclear bands that were not included in the analysis. The SSR markers were scored as co-dominant markers, and the results are summarized in Table 2.

**Table 1.** The total information of 76 SSR primers used in this study.

Marker name	Unit	Annealing temperature (°C)	Expected size (bp)	Primer sequence (5'–3')
ivflmre8	(GTCGGA) <sub>4</sub>	56	247	F: CAGGTGATGCCAGAGGTACT R: ATACCCTTTCCTATCGCTCC
ivflmre14	(GGA) <sub>6</sub>	54	101	F: TAAGCGGATGAGGTAATGG R: ACAGCTTCTGGGCGGCAGACA
ivflmre24	(AAAAT) <sub>3</sub>	56	385	F: TCTGACCGTACAAGCTCCA R: ATTATGTGCTGGCTTTTCG
ivflmre32	(GGA) <sub>8</sub>	55	151	F: AGAGGAAGAGAGCTCGCGTC R: AGCAGTCCCAACTCTCGATG
ivflmre39	(CT) <sub>7</sub>	55	245	F: AGGGTCAAAGAAGCGTGG R: CCCAACCTCATCCCCAGA
ivflmre43	(GGA) <sub>5</sub>	54	145	F: CGTGGTAGGTTAGGATCGAG R: AGGGTTTTGCTCTCTGATGA
ivflmre53	(CCT) <sub>5</sub>	46	136	F: GAGAACAACCAGAGCGCC R: TCACAAACACAGCCTCAGAC
ivflmre70	(CCT) <sub>5</sub>	58	302	F: CGCTTCATTCCACTCACC R: GTCTTGTCTTCCTTCGCC
ivflmre105	(AAAACA) <sub>3</sub>	55	267	F: ACAGCAGAAAACACCACCTA R: AAATCCGACTAACATTACACA
ivflmre108	(CT) <sub>10</sub>	57	141	F: TGCCTCTTCACGAATCCCA R: ACCGGTCGGTCGAGAAGAT
ivflmre115	(GCC) <sub>5</sub>	56	168	F: GCACAGAGGGACCAAAAAGA R: CGTGAGTTCGATGTCCTGGT
ivflmre158	(CAATC) <sub>3</sub>	54	146	F: TACCCCAATCTTTTCATCAT R: GCGCAGGGATTAGTGTATAG
ivflmre167	(CCT) <sub>6</sub>	56	169	F: TACTGCCGAGGATGACGAAC R: AGGAAGGTGAGGGTGAACAT
ivflmre168	(AGCAGA) <sub>3</sub>	55	205	F: CACTTAAAGCCCAATCTGAT R: CTTCTTAGGGTGGACATAGC

**Table 1.** Continued.

Marker name	Unit	Annealing temperature (°C)	Expected size (bp)	Primer sequence (5'–3')
ivflmre434-F	(CTGAT) <sub>4</sub>	55	234	GAGCATTAGCCCCTGGT
ivflmre434-R				GCCACTTTGCGGGTAGAA
ivflmre436-F	(TCC) <sub>5</sub>	55	212	GAGCGGTAGTCGGTATC
ivflmre436-R				AGCTTCATCCCTTTCTC
ivflmre439-F	(AG) <sub>13</sub>	57	119	AAAATTAGTGTGCGAGGAAGG
ivflmre439-R				GTGCGAGACTGACAGAACAT
ivflmre444-F	(GCATCA) <sub>3</sub>	54	332	TTCTCCTGGATCGCTGT
ivflmre444-R				CGGTAGAATAGCGGGTTG
ivflmre453-F	(GAA) <sub>6</sub>	35	282	AGACAAGGACCCTAACACAG
ivflmre453-R				GACAATTCCGCTGATAAAG
ivflmre455-F	(GAGG) <sub>4</sub>	56	109	TAAGGTGGTGTCAAGGGAGT
ivflmre455-R				TCTATGCACCGTCTATTTCC
ivflmre473-F	(TTTCTT) <sub>3</sub>	56	132	ATCTTCTCCTCCTCGGTG
ivflmre473-R				CCCTATCCCTGTGTCTGC
ivflmre474-F	(CCACCG) <sub>4</sub>	55	221	CTAGCCGCCCTTTCCCTT
ivflmre474-R				CGCCTTGATGTCTCCAG
ivflmre484-F	(CTC) <sub>5</sub>	53	123	TTGCTTTTGGCTGAATGC
ivflmre484-R				GTTGGTGGTGAGGTTGGAG
ivflmre486-F	(GAGTTC) <sub>3</sub>	55	126	GCCCAACCCACTCTTCTC
ivflmre486-R				GCTGCTGAATATGCCCTC

ivflmre488-F	(AGA) <sub>5</sub>	55	109	AGGGGTCTAAATGATGTT
ivflmre488-R				GGAGGGATGAGATGGAGT
ivflmre489-F	(ATTTT) <sub>3</sub>	57	238	TGAGGGCGACGAGGAAGA
ivflmre489-R				AGGCGCAGACCAAAATTG
ivflmre490-F	(TTTTA) <sub>3</sub>	54	151	GCAATAACAGGAAGGCTACA
ivflmre490-R				CGGAATCTCAAACATGTACC
ivflmre492-F	(TTA) <sub>6</sub>	35	272	CGGGAAGTAATACAAGCACA
ivflmre492-R				GGAGGGTATGACAGGTTGAT
ivflmre494-F	(CAG) <sub>7</sub>	56	127	ACTTGCAGATGTCGAGGC
ivflmre494-R				TGTTGCGGCATCGTCTTA
ivflmre515-F	(TCC) <sub>5</sub>	56	139	CCAATGGAGAGCACAGAGC
ivflmre515-R				CGTCAGTGGTTTTGGGAGT
ivflmre524-F	(GGAGCC) <sub>3</sub>	55	137	AGTCGAGATCGGCCGGGT
ivflmre524-R				CATCCTTAAACCCTAGTTCTACCT
ivflmre530-F	(CCG) <sub>5</sub>	53	130	TTTTAAGGAATCCGGCACT
ivflmre530-R				GCTCGGGAAAGAGGGATG
ivflmre533-F	(TAGGGT) <sub>3</sub>	57	117	TCATTGTCCCCAAGCTC
ivflmre533-R				CGGTTCTCGGCTTGTTCT
ivflmre543-F	(CTT) <sub>5</sub>	54	236	AAAGATGTCGTTGATGAAGC
ivflmre543-R				AGGAAAAGGAGGAGGTGC
ivflmre544-F	(CGG) <sub>5</sub>	35	114	AGAGGATCGATGAGTAGGCC
ivflmre544-R				CTTAGCCGAGCGAGCAGA

Table 1. Continued.

Marker name	Unit	Annealing temperature (°C)	Expected size (bp)	Primer sequence (5'-3')
ivflmre170-F	(TGTGGA) <sub>3</sub>	56	184	GGAACCGAGCTATTGACTGA
ivflmre170-R				ATTTCTCAAACGGCAACTGT
ivflmre174-F	(CGC) <sub>5</sub>	55	126	AGAAACCAAAGCTTGAGCAG
ivflmre174-R				ACCAGTTGGCTTCTTCTCT
ivflmre178-F	(CCTCT) <sub>3</sub>	53	270	CAACAATGGCATCACCAAAT
ivflmre178-R				GGAGGATGGAGTTGAAGACG
ivflmre181-F	(AGC) <sub>5</sub>	57	142	GGAGGATGGATGCCGATACC
ivflmre181-R				CCCACATCGTATCCGAGAAGA
ivflmre186-F	(CTC) <sub>5</sub>	54	218	CAAAACCTCATCGGTGCTAG
ivflmre186-R				AGAGACGAGATGCAGAGGGT
ivflmre187-F	(CTT) <sub>5</sub>	35	114	TCTTCATTATCAGCATCACTC
ivflmre187-R				TCTGTCAAGTATTCTAACCAAG
ivflmre189-F	(ACAT) <sub>5</sub>	56	248	CATTTAATCCTCGTTATTCACT
ivflmre189-R				GTGTA AAAAGCAACATGGTCG
ivflmre200-F	(CGC) <sub>5</sub>	56	222	TCCCGAATCACAAACCTATC
ivflmre200-R				GATGTCAATGATGGAGGAGA
ivflmre413-F	(TGC) <sub>5+</sub>	55	253	GATATTGCCTGCGGGAGA
ivflmre413-R	(GCTGTT) <sub>3</sub>			CTCGTAACCCGACGCAGA
ivflmre421-F	(GCAGGA) <sub>3</sub>	55	310	TTCAGATCGGACCAGACG
ivflmre421-R				CAACTACTCCAGCAACGAC
ivflmre422-F	(GTTAGG) <sub>3</sub>	57	122	GAAATAAATCCCACCCAA
ivflmre422-R				CTGACAACCTCCAGCCAAC
ivflmre428-F	(CTACTC) <sub>3</sub>	54	155	TTTGTA AAAAGGGAAGCTGC
ivflmre428-R				TCTAAATCAGGAAGCTCGTA
ivflmre429-F	(CCTCT) <sub>3</sub>	35	198	ATGGCTGGCTATGAAATC
ivflmre429-R				GCAGCTAATCCGAAACTTG
ivflmre433-F	(AGGGTT) <sub>3</sub>	56	275	GAAGCAGCAATCAAGCACC
ivflmre433-R				ACCCAATTCTCATCCTCGC
ivflmre573-F	(GA) <sub>8</sub>	56	100	TAAATGCTAAACCCACCTTG
ivflmre573-R				ATCGTGTGGATTGATGGTG
ivflmre558-F	(GAGCCG) <sub>3</sub>	55	139	CTCATTGTCCGAAAGCTC
ivflmre558-R				CCAGTCATTCTCTTCTCT
ivflmre568-F	(TGG) <sub>5</sub>	55	160	GTTTTTCTTGATCCCGGTG
ivflmre568-R				CGACCCCGATCGGAACTC

ivflmre581-F	(GGGAAG) <sub>3</sub>	55	218	GCCGTGGGAGATCATAGAG
ivflmre581-R				CAACATTGTCAGGCAGAGC
ivflmre593-F	(AACC) <sub>4</sub>	57	105	TATTTGTGCTCCTTGCCCTG
ivflmre593-R				ATGAGAAGGGGCAGTGATG

Table 1. Continued.

Marker name	Unit	Annealing temperature (°C)	Expected size (bp)	Primer sequence (5'-3')
ivflmre598-F	(TTAG) <sub>6</sub>	57	138	GATGGTCAAAGAGTTGTATGGA
ivflmre598-R				GGCGATTATTCAGGCTCAC
ivflmre604-F	(TC) <sub>7</sub>	54	114	GATGAAAGTGGTCGTCGG
ivflmre604-R				CTTCGTCCGAGGAATAATC
ivflmre612-F	(AG) <sub>7</sub>	35	143	AGAGACGCGGAGGAGAAG
ivflmre612-R				TCGGGAGACGATGAAACC
ivflmre617-F	(TGCAGGGGG) <sub>3</sub>	56	136	GAGAGGACGACGGTAACG
ivflmre617-R				GGACATCTTCTCCGAGCG
ivflmre633-F	(ATCTTT) <sub>3</sub>	56	127	TGCTCGCCCGATAAATCA
ivflmre633-R				AGCCGAGGGTGGAGGAAT
ivflmre635-F	(GA) <sub>7</sub>	55	121	ACCCAGCAAAAATCCAACC
ivflmre635-R				AAGCCGCCGATGAACAGG
ivflmre642-F	(CTT) <sub>5</sub>	53	110	GCCGCACCAACCTCCAAC
ivflmre642-R				GGCGCCGTCAAGAAAGTC
ivflmre645-F	(TCC) <sub>5</sub>	53	130	GCCCAAGAAGCGGAAGAG
ivflmre645-R				AAGGTTGCCGAGGGGTTG
ivflmre690-F	(AAG) <sub>6</sub>	57	138	GATGGTGGGGCTGACAAG
ivflmre690-R				GGGGAAGCTACAGGAGGC
ivflmre692-F	(GGA) <sub>5</sub>	54	137	CAACAGAGGCTGGCAATG
ivflmre692-R				CGCCGGAAGATGTAGAAT
ivflmre706-F	(AGA) <sub>6</sub>	35	136	ACCCTAGATTCGCCGCTG
ivflmre706-R				CCGCCGCATCTGATTCCT
ivflmre713-F	(GGA) <sub>5</sub>	56	100	GAGGTGAACACTCCAGCAG
ivflmre713-R				GTCTCAGATCTCGTGCCG
ivflmre731-F	(AAG) <sub>6</sub>	56	224	TCCTCCCTGAAAGAATACCTC
ivflmre731-R				CGCTTCATCCGTTAACCTC
ivflmre770-F	(CTCCCT) <sub>3</sub>	55	294	ATCCGCACCATCTTCACC
ivflmre770-R				TCCAATCCCATCACCTC
ivflmre794-F	(TAG) <sub>5</sub>	55	294	CTGCTGAGCGAGGAAATG
ivflmre794-R				GTAAAAGCATGGTTCTTGAGGT
ivflmre804-F	(TTCTCC) <sub>3</sub>	57	189	TGACCTCCTTCGTCTTATCC
ivflmre804-R				TCACCAAGAAGCTGTACTGC
ivflmre826-F	(CT) <sub>8</sub> +(CCT) <sub>5</sub>	55	397	CGGCCGTCACTTATCAACTC
ivflmre826-R				CAACAGTGGGGCACGGAG
ivflmre852-F	(GAG) <sub>5</sub>	55	299	GGATAAGCGAGCAGAGGT
ivflmre852-R				GTTGCTTTTCGCTTGTGC
ivflmre854-F	(TCACC) <sub>3</sub>	55	144	TCCGTTCTCTATTGTCCG
ivflmre854-R				CGAAACCCTAGATCCACTC
ivflmre858-F	(GGC) <sub>5</sub>	54	269	CAGCAACACCGACAACGA
ivflmre858-R				CGCCCAATCTCACCCAGT
ivflmre877-F	(TTCCC) <sub>3</sub>	53	278	CGCCTTCTTCAGCCTCTT
ivflmre877-R				CAAGCTCCCTGCAACTCC
ivflmre891-F	(CTTCTC) <sub>3</sub>	55	141	TTAGCGTTAGCGGACCTG
ivflmre891-R				AAACGGATGGATGGCAGA

**Table 2.** Classification type codes, number of locus and possible genotypes in CP model of JoinMap 4.

Marker type	Number of locus	Code	Possible genotypes
SSR	151	hk×hk	h-/hk/kk
		lm×ll	ll/lm
		nn×np	nn/np
		hk×hk	h_/kk
AFLP	465	lm×ll	ll/lm
		nn×np	nn/np

Note: “\_” means unknown allele.

### ***AFLP primers results***

A total of 40 AFLP primers from each EcoRI + 3/MseI + 3 combinations were initially used to generate 634 primer combinations, which were tested on 6 plants (2 parents and 4 progeny). From these, the 96 most effective primer combinations were selected for testing across the

entire population (Table 3, Figs. S3 and S4). These selected combinations produced 465 clearly segregating AFLP markers, along with some faint and unclear bands that were not included in the scoring. The AFLP markers were scored as dominant markers (Table 2).

**Table 3.** The total *EcoRI* and *MseI* primer combinations tested in all population.

<b><i>EcoRI</i> and <i>MseI</i> primer combinations</b>			
E-AAC/M-CTA	E-CGA/M-CGC	E-GCG/M-TTC	E-GGT/M-TAC
E-AAC/M-CTG	E-CGA/M-CGG	E-GCG/M-TTT	E-GGT/M-TCG
E-ACC/M-CAA	E-CGA/M-CGT	E-GCT/M-CGA	E-GTC/M-AGC
E-ACC/M-CAC	E-CGC/M-CCC	E-GCT/M-CGC	E-GTC/M-CGC
E-ACC/M-CTA	E-CGC/M-CCT	E-GCT/M-CGT	E-GTC/M-CGG
E-ACG/M-AAC	E-CGC/M-CGA	E-GGA/M-AAC	E-GTC/M-CGT
E-ACG/M-CAC	E-CGC/M-CGC	E-GGA/M-AAG	E-GTC/M-TCC
E-ACG/M-CAG	E-CGC/M-CGG	E-GGA/M-AGT	E-GTC/M-TCG
E-ACG/M-CAT	E-CGC/M-CGT	E-GGA/M-TAG	E-GTG/M-CGC
E-ACG/M-CTA	E-CGC/M-TCG	E-GGA/M-TCA	E-GTG/M-CGG
E-ACG/M-TAG	E-GAG/M-AAG	E-GGA/M-TTG	E-GTG/M-CGT
E-ACG/M-TCA	E-GAG/M-ATG	E-GGC/M-CGA	E-GTT/M-AGC
E-ACG/M-TTG	E-GAG/M-TTG	E-GGC/M-CGC	E-GTT/M-CGC
E-AGC/M-CAA	E-GAT/M-TCA	E-GGC/M-CGG	E-GTT/M-CGG
E-AGC/M-CAC	E-GCA/M-TAG	E-GGC/M-CGT	E-GTT/M-CGT
E-AGC/M-CAG	E-GCA/M-TCT	E-GGG/M-CGA	E-GTT/M-TAA
E-AGC/M-CTC	E-GCA/M-TGG	E-GGG/M-CGC	E-GTT/M-TCC
E-AGC/M-CTG	E-GCA/M-TTC	E-GGG/M-CGG	M-CCG/E-GGC
E-AGC/M-CTT	E-GCC/M-CGC	E-GGG/M-CGT	M-CCG/E-GGT
E-AGG/M-CAG	E-GCC/M-CGG	E-GGG/M-TCG	M-CTG/E-GAG
E-AGG/M-CAG	E-GCC/M-CGT	E-GGT/M-CCT	M-CTG/E-GTA
E-CAG/M-CGA	E-GCG/M-AGC	E-GGT/M-CGA	E-GGT/M-CGT
E-CAG/M-CGC	E-GCG/M-CGC	E-GGT/M-CGC	E-GCG/M-TGG
E-CAG/M-CGG	E-GCG/M-CGG	E-GGT/M-CGG	E-CAG/M-CGT

### ***Construction of genetic linkage maps***

The F<sub>1</sub> population used for linkage map development consisted of 100 individuals. The CP (cross pollinators, outbreeder full-sib family) model was employed to construct maps for both parents and their progeny simultaneously. Marker clustering was performed using an independence LOD score set between 2 and 10, with linkage maps constructed for groups with LOD values ranging from 3 to 5. Table 4 provides

an overview of the linkage maps. In total, 189 loci were mapped, including 152 AFLP markers and 47 SSR markers, with an overall mapped length of 2144.2 cM.

### ***Maternal linkage maps***

A total of 12 maternal linkage groups were constructed using 52 loci. The Lilium ‘Sorbonne’ map spanned a total length of 861.6 cM, with an average interval of 13.255 cM between adjacent



loci (Table 5). The lengths of the linkage groups ranged from 15.7 to 165.9 cM. The shortest gap of 2.2 cM was observed in linkage groups LG-M7 and LG-M8. Figure 1 illustrates the 12 maternal linkage groups. The overall analysis of these linkage groups revealed that the number of

markers per group varied from 3 to 7. Linkage group LG-M9 contained the highest number of DNA markers (7), whereas LG-M3, LG-M4, LG-M5, LG-M11, and LG-M12 each contained the fewest, with only 3 markers each. On average, each linkage group contained 4.33 markers.

**Table 4.** The total information of the Genetic linkage map of this study.

Plant information	Number of linkage groups	Number of mapped loci	Length (cM)	Number of AFLP marker mapped loci	Number of SSR marker mapped loci	Shortest gap on LGs (cM)	Largest gap on LGS (cM)
Paternal map	12	51	676	46	5	0.1	47.7
Maternal map	12	52	861.6	42	10	2.2	55.7
Integrated map	6	86	606.6	54	32	0.2	26.8
<b>Total</b>	<b>30</b>	<b>189</b>	<b>2144.2</b>	<b>152</b>	<b>47</b>	<b>-</b>	<b>-</b>

**Table 5.** Total information of the genetic linkage map of the maternal (*Lilium* ‘Sorbonne’).

Linkage groups (LGs)	Maternal map ( <i>Lilium</i> “Sorbonne”)				
	Number of mapped loci	Length (cM)	Average locus distance (cM)	Shortest gap on LGs (cM)	Largest gap on LGs (cM)
LG-M1	5	97	19.4	15.8	40.1
LG-M2	6	98.1	16.35	12	26
LG-M3	3	48.9	16.3	21.3	27.6
LG-M4	3	36.3	12.1	11.4	24.9
LG-M5	3	41.9	13.966	6.6	35.3
LG-M6	4	61.2	15.3	4.9	41.2
LG-M7	4	15.7	3.925	2.2	11.5
LG-M8	6	69.7	11.616	2.2	20
LG-M9	7	165.9	23.7	8.7	41.5
LG-M10	5	127.5	25.5	19.9	55.7
LG-M11	3	57.5	19.166	21	36.5
LG-M12	3	41.9	13.966	19.4	22.5
<b>Total</b>	<b>52</b>	<b>861.6</b>	<b>-</b>	<b>145.4</b>	<b>382.8</b>
<b>Average</b>	<b>4.33</b>	<b>78.327</b>	<b>13.255</b>	<b>12.116</b>	<b>31.9</b>

### **Paternal linkage maps**

The *Lilium* ‘Gaudi’ maps consisted of 12 linkage groups, constructed using 51 mapped loci, and were designated LG-F1 to LG-F12. The paternal framework maps covered a total linkage length of 676 cM, with an average interval of 22.494 cM between adjacent loci. The lengths of the linkage groups ranged from 22.9 cM in LG-F12 to 169.4 cM in LG-F3. The smallest gap between markers was 0.1 cM, observed in LG-F3, while the largest

gap of 47.7 cM was found in LG-F11 (Table 6). The results also showed an average loci count of 4.25 per linkage groups. The number of mapped loci also varied from 2 to 15. The linkage group LG-F3 contained the highest number of mapped loci (15), whereas LGs LG-F10, LG-F11 and LG-F12 had the lowest number, each with only 2 mapped loci. Figure 2 shows the total information of paternal linkage groups.



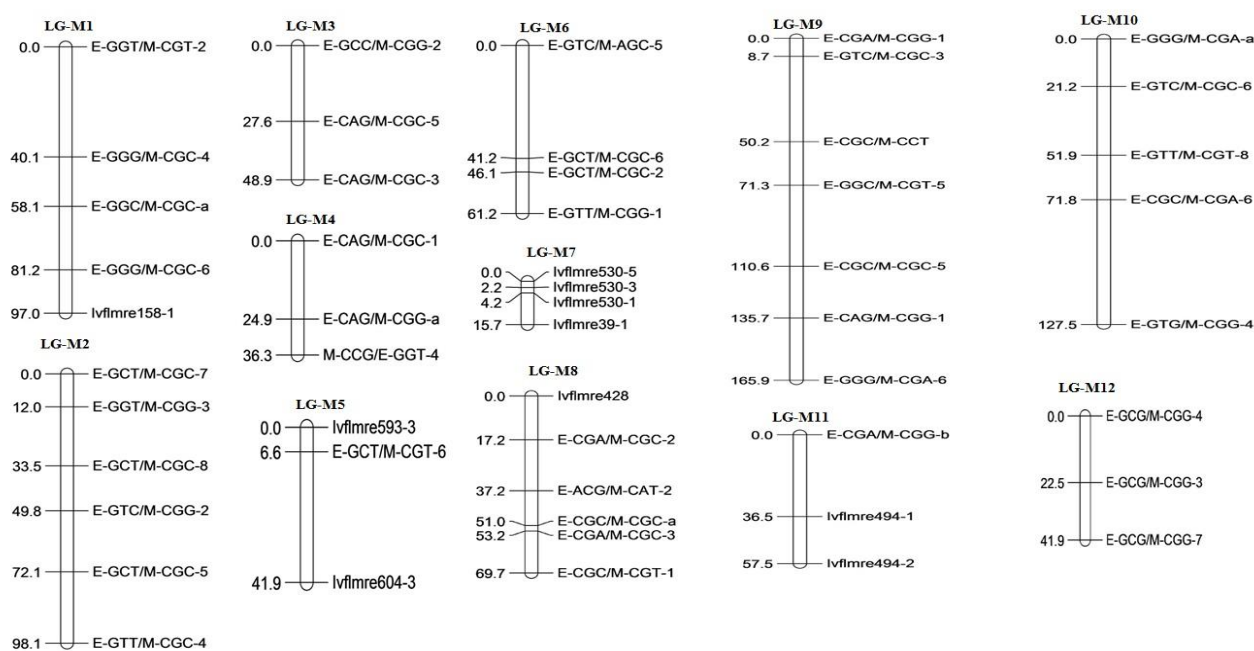

**Fig. 1.** Genetic linkage map of the female parent showing the location of 52 loci distributed over 12 linkage groups. Segregation data is based on 42 AFLP loci and 10 SSR loci. Locus nomenclature for AFLP markers is shown as follows: E-GGT/M-CGT refers to the *EcoRI/MseI* primer combinations as coded on the above tables. The LG-M also refers to the maternal linkage groups numbered from 1 to 12.

**Table 6.** Total information of the genetic linkage map of the male parent (*Lilium* ‘Gaudi’).

Linkage groups (LGs)	Paternal map ( <i>Lilium</i> “Gaudi”)				
	Number of mapped loci	Length (cM)	Average locus distance (cM)	Shortest gap on LGs (cM)	Largest gap on LGs (cM)
LG-F1	3	51.4	17.133	19.2	32.2
LG-F2	5	43.5	8.7	1.4	15.1
LG-F3	15	169.4	11.293	0.1	41.3
LG-F4	6	101.9	16.983	4.2	34.1
LG-F5	4	64.5	16.125	13.5	36.3
LG-F6	3	28	9.333	3.6	24.4
LG-F7	3	40.4	13.467	11.3	29.1
LG-F8	3	54.4	18.133	25	29
LG-F9	3	26	8.666	2.2	23.8
LG-F10	2	26.2	13.1	26.2	26.2
LG-F11	2	47.4	23.7	47.7	47.7
LG-F12	2	22.9	11.45	22.9	22.9
Total	51	676	-	177.3	362.1
Average	4.25	56.333	22.494	14.775	30.175

**Integrated progeny linkage maps**

The genetic linkage map for the integrated progeny of the OO lily population comprised 6 linkage groups, designated LG-F1P1 to LG-F1P6. In total, 86 loci were mapped, with an average of 14.333 loci per linkage group. These 6 linkage groups spanned a total length of 606.6 cM. The smallest gap between markers was 4.037 cM in LG-F1P1. The shortest linkage group gap was 0.2 cM, while the longest was 34 cM, found in LG-

F1P1 and LG-F1P6, respectively. The lengths of the linkage groups ranged from 33 cM in LG-F1P4 to 161.5 cM in LG-F1P1, with an average distance of 7.053 cM between adjacent mapped loci (Table 7).

The number of mapped loci in the integrated population ranged from 4 to 40. The highest density genetic linkage map was observed in LG-F1P1, which contained 40 mapped loci, followed by LG-F1P2 with 20 mapped loci, with an average

distance of 7.09 cM between adjacent loci. In LG-F1P1, SSR markers were more numerous than AFLP markers, and the gaps between adjacent SSR markers were completely filled by AFLP markers. Conversely, in LG-F1P2, the gaps between AFLP markers were covered by SSR

markers. The linkage groups LG-F1P4 and LG-F1P6 had the lowest density, each containing only 4 mapped loci. Figure 3 provides an overview of the linkage groups for the integrated progeny.

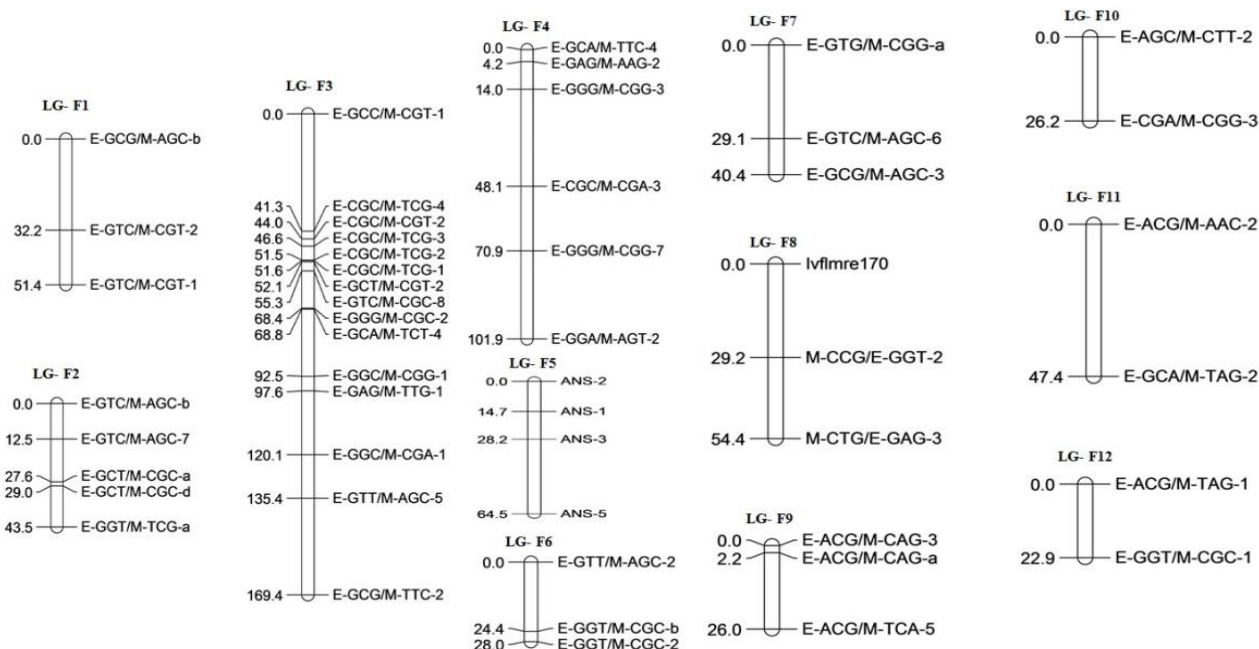

**Fig. 2.** Genetic linkage map of the male parent showing the location of 51 loci distributed over 12 linkage groups. Segregation data is based on 46 AFLP loci and 5 SSR loci. Locus nomenclature for AFLP markers is shown as follows: E-GGT/M-CGT refers to the *EcoRI/MseI* primer combinations as coded on the above tables. The LG-F refers to the paternal linkage groups numbered 1-12.

**Table 7.** Total information of the genetic linkage map of the OO lily population (integrated progeny).

Linkage groups (LGs)	OO lily population map (integrated progeny)				
	Number of mapped loci	Length (cM)	Average locus distance (cM)	Shortest gap on LGs (cM)	Largest gap on LGs (cM)
LG-F1P1	40	161.5	4.037	0.2	23
LG-F1P2	20	141.8	7.09	0.4	18
LG-F1P3	11	112.2	10.2	1.5	26.8
LG-F1P4	4	33	8.25	7.1	13.4
LG-F1P5	6	81.8	13.633	9.5	26.1
LG-F1P6	4	76.3	19.075	18.8	34
<b>Total</b>	86	606.6	-	37.5	141.3
<b>Average</b>	14.333	101.1	7.053	6.25	23.55

**Discussion**

To date, comprehensive studies on genetic mapping in lilies have been limited. Previous research utilized ISSR and RAPD markers to construct linkage maps for anthocyanin and carotenoid pigmentations in progeny from a cross between *Lilium* 'Montreux' and 'Connecticut King' (Asiatic hybrids) (Abe et al., 2002; Nakano et al., 2005). Additionally, AFLP and RAPD markers

were employed to map Fusarium resistance in progeny from a cross between 'Connecticut King' and 'Orlito' (Asiatic hybrids) (Van Heusden et al., 2001). This study presents the first individual linkage maps for *Lilium* 'Gaudi' (male), *Lilium* 'Sorbonne' (female), and their progeny. Apart from our study, only one other report describes a genetic linkage map of Asiatic lily hybrids, as noted above.

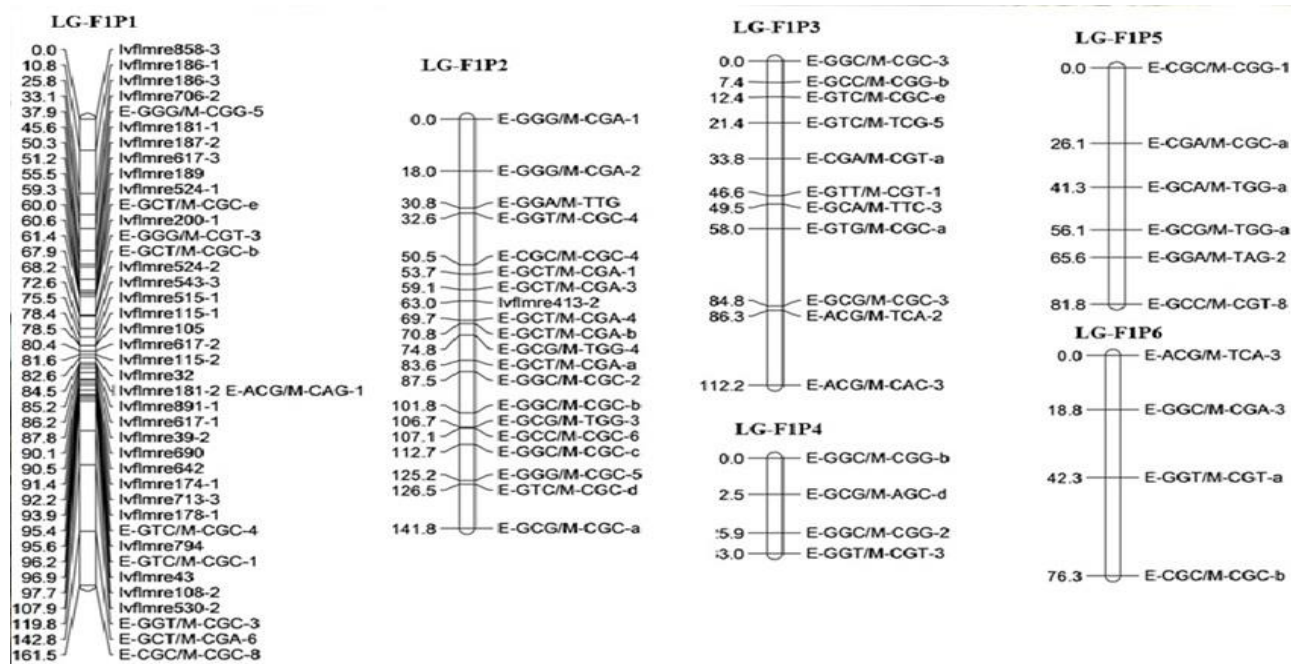

**Fig. 3.** Genetic linkage map of OO lily population (integrated progeny) showing the location of 86 loci distributed over 6 linkage groups. Segregation data is based on 54 AFLP loci and 32 SSR loci. Locus nomenclature for AFLP markers is shown as follows: E-GGT/M-CGT refers to the *EcoRI*/*MseI* primer combinations as coded on the above tables. The LG-F1P refers to the integrated linkage groups numbered 1-6.

Our study is the first to construct linkage maps using AFLP and SSR markers in 100 OO F1 progenies, providing a foundational resource for mapping this important section of the lily family. This work identified significant quantitative trait loci (QTLs) affecting key phenotypes of lilies. The map revealed 30 linkage groups (12 paternal, 12 maternal, and 6 integrated), covering a total genome length of 2144.2 cM. Abe et al. (2002) also developed a linkage map for Asiatic lilies using 96 F1 plants and 212 PCR-based DNA markers. Similar to Crespel et al. (2002) in roses, we combined AFLP and SSR markers to enhance the genetic map. Crespel et al. (2002) found that adding SSR markers significantly improved genome coverage and linkage group definition. Marker density varied in our maps: 1 marker per 13.25 cM for maternal maps, 16.56 cM for paternal maps, and 7.05 cM for integrated maps. In contrast, Abe et al. (2002) reported densities of 1 marker per 7.79 cM and 6.52 cM for maternal and paternal maps, respectively. The integrated map density was comparable. Our maps also exhibited several large gaps, similar to findings by Yu et al. (2012) in anthuriums, highlighting the need for further mapping. Incorporating additional SSR, AFLP, or other marker types from studies on lilies (Abe et al., 2002), roses (Yan et al., 2005), or other Liliaceae species could address these gaps and further saturate the maps.

The distribution of AFLP markers varied across species, with some showing random distribution (Cervera et al., 2001; Shen et al., 2005) and others clustering (Sakamoto et al., 2000; Waldbieser et al., 2001). In our study, the number of markers per linkage group ranged from 2 to 40, with LG-F1P1 containing the highest number. Chen and Chen (2010) reported that their linkage maps of *Chimonanthus praecox* (L.) Link, the first intraspecific genetic linkage maps, mostly had linkage groups with only 2 markers.

The CP (cross pollinators, outbreeder full-sib family) model used in our study was first implemented in forest trees by Grattapaglia and Sederoff (1994) to construct linkage maps of interspecific full-sib crosses in Eucalyptus. This approach resulted in three types of segregating markers: (a) markers inherited from the pollen parent (paternal plant), (b) markers inherited from the seed parent (maternal plant), and (c) markers inherited from both parents (F<sub>1</sub> progeny). A LOD score greater than 3.0 is considered indicative of linkage; higher LOD scores enhance the quality of linkage maps. In this study, the LOD scores ranged from 3.0 to 0.5.

The number of linkage groups in *Lilium* 'Gaudi' and *Lilium* 'Sorbonne' was 12 each, while the integrated progeny had 6 linkage groups. Based on linkage mapping theory, the number of linkage groups should correspond to the number of

haploid chromosomes. The fewer linkage groups observed in integrated plants ( $n = 12$ ) suggest that the maps are not fully saturated. To improve map saturation, additional markers and larger population sizes are needed. Among the 616 scored loci, many were unlinked, contributing to less saturated maps, as noted by Yu et al. (2012).

## Conclusions

This study represents the first genetic linkage map for OO lily populations using AFLP and SSR markers. It identifies several important ornamental characteristics of the lily flower, including flower circumference, petal length, petal width, spot size, spot number, plant height, leaf number, flower number, and flower vase life. These traits are detailed in our previous publication (Pourbeyrami-Hir et al., 2019), which suggests that these findings could significantly impact the ornamental plant industry. The genetic linkage maps developed in this study will serve as a valuable reference for oriental lilies and will facilitate the mapping of quantitative trait loci (QTLs) associated with various traits. Additionally, the information may aid in improving breeding programs for oriental lilies. By identifying the locations of relevant genes and their corresponding chromosome primers, this study provides a foundation for future research and applications in lily breeding and genetic improvement.

## Conflict of Interest

The authors indicate no conflict of interest in this work.

## References

- Abe H, Nakano M, Nakatsuka A, Nakayama M, Koshioka M, Yamagishi M. 2002. Genetic analysis of floral anthocyanin pigmentation traits in Asiatic hybrid lily using molecular linkage maps. *Theoretical and Applied Genetics* 105, 1175-1182.
- Cervera M.-T, Storme V, Ivens B, Gusmao J, Liu B.H, Hostyn V, Van Slycken J, Van Montagu M, Boerjan W. 2001. Dense genetic linkage maps of three *Populus* species (*Populus deltoides*, *P. nigra* and *P. trichocarpa*) based on AFLP and microsatellite markers. *Genetics* 158, 787-809.
- Chen D.-W, Chen L.-Q. 2010. The first intraspecific genetic linkage maps of wintersweet [*Chimonanthus praecox* (L.) Link] based on AFLP and ISSR markers. *Scientia Horticulturae* 124, 88-94.
- Crespel L, Chirollet M, Durel C, Zhang D, Meynet J, Gudín S. 2002. Mapping of qualitative and quantitative phenotypic traits in *Rosa* using AFLP markers. *Theoretical and Applied Genetics* 105, 1207-1214.
- Danesh M, Lotfi M, Azizinia S. 2015. Genetic diversity of Iranian melon cultigens revealed by AFLP markers. *International Journal of Horticultural Science and Technology* 2, 43-53.
- Das M, Banerjee S, Dhariwal R, Vyas S, Mir R.R, Topdar N, Kundu A, Khurana J.P, Tyagi A.K, Sarkar D. 2012. Development of SSR markers and construction of a linkage map in jute. *Journal of Genetics* 91, 21-31.
- Grattapaglia D, Sederoff R, 1994. Genetic linkage maps of *Eucalyptus grandis* and *Eucalyptus urophylla* using a pseudo-testcross: mapping strategy and RAPD markers. *Genetics* 137, 1121-1137.
- Hibrand-Saint Oyant L, Crespel L, Rajapakse S, Zhang L, Foucher F. 2008. Genetic linkage maps of rose constructed with new microsatellite markers and locating QTL controlling flowering traits. *Tree Genetics & Genomes* 4, 11.
- Kiran U, Khan S, Mirza K.J, Ram M, Abdin M. 2010. SCAR markers: a potential tool for authentication of herbal drugs. *Fitoterapia* 81, 969-976.
- Morgante M, Rafalski A, Biddle P, Tingey S, Olivieri A, 1994. Genetic mapping and variability of seven soybean simple sequence repeat loci. *Genome* 37, 763-769.
- Nakano M, Nakatsuka A, Nakayama M, Koshioka M, Yamagishi M. 2005. Mapping of quantitative trait loci for carotenoid pigmentation in flower tepals of Asiatic hybrid lily. *Scientia Horticulturae* 104, 57-64.
- Nakatsuka T, Yamada E, Saito M, Hikage T, Ushiku Y, Nishihara M. 2012. Construction of the first genetic linkage map of Japanese gentian (*Gentianaceae*). *BMC Genomics* 13, 1-15.
- Nayak S.N, Zhu H, Varghese N, Datta S, Choi H.-K, Horres R, Jüngling R, Singh J, Kishor P.K, Sivaramakrishnan S. 2010. Integration of novel SSR and gene-based SNP marker loci in the chickpea genetic map and establishment of new anchor points with *Medicago truncatula* genome. *Theoretical and Applied Genetics* 120, 1415-1441.
- Nickraves M.H, Vahdati K, Amini F, Di Pierro E.A, Amiri R, Woeste K, Arab M.M. 2023. Reliable propagation of Persian walnut varieties using SSR marker-based true-to-type validation. *HortScience* 58, 64-66.
- Pourbeyrami-Hir Y, Yuan S, Gíglou M.T, Jun M. 2019. QTLs position of some important ornamental traits in recently developed OO lily population. *Physiology and Molecular Biology of Plants* 25, 1419-1434.
- Sakamoto T, Danzmann R.G, Gharbi K, Howard P, Ozaki A, Khoo S.K, Woram R.A, Okamoto N, Ferguson M.M, Holm L.-E. 2000. A microsatellite linkage map of rainbow trout (*Oncorhynchus mykiss*) characterized by large sex-specific differences in recombination rates. *Genetics* 155, 1331-1345.
- Shahin A, Arens P, Van Heusden A.W, Van Der Linden G, Van Kaauwen M, Khan N, Schouten H.J, Van De Weg W.E, Visser R.G, Van Tuyl J.M. 2011. Genetic mapping in *Lilium*: mapping of major genes and quantitative trait loci for several ornamental traits and disease

resistances. *Plant Breeding* 130, 372-382.

Shen X, Guo W, Zhu X, Yuan Y, John Z.Y, Kohel R.J, Zhang T. 2005. Molecular mapping of QTLs for fiber qualities in three diverse lines in Upland cotton using SSR markers. *Molecular Breeding* 15, 169-181.

Tang S, Okashah R.A, Cordonnier-Pratt M.-M, Pratt L.H, Johnson V.E, Taylor C.A, Arnold M.L, Knapp S.J. 2009. EST and EST-SSR marker resources for Iris. *BMC Plant Biology* 9, 1-11.

Tokgöz H.B, Çetin Ö, Kaya H.B, Akkale C, Yildirim H, Pirhan A.F, Kaya E, Altan F. 2024. Genetic diversity of *Lilium candidum* natural populations in Türkiye evaluated with ISSR and M13-tailed SSR markers. *Plant Systematics and Evolution* 310, 5.

Van Heusden AW, Jongerius MC, Van Tuyl JM, Straathof TP, Mes J. 2001. Molecular assisted breeding for disease resistance in lily, XX International Eucarpia Symposium, Section Ornamentals, Strategies for New Ornamentals-Part II 572, pp. 131-138.

Van Tuyl J.M, Arens P, Ramanna M, Shahin A, Khan N, Xie S, Marasek-Ciolakowska A, Lim K.-B, Barba-Gonzalez R. 2011. *Lilium*, Wild Crop Relatives: Genomic and Breeding Resources. Springer, pp. 161-183.

Vos P, Hogers R, Bleeker M, Reijans M, Lee T.v.d, Hornes M, Friters A, Pot J, Paleman J, Kuiper M, 1995. AFLP: a new technique for DNA fingerprinting. *Nucleic Acids Research* 23, 4407-4414.

Waldbieser G.C, Bosworth B.G, Nonneman D.J, Wolters W.R. 2001. A microsatellite-based genetic linkage map for channel catfish, *Ictalurus punctatus*. *Genetics* 158, 727-734.

Winter P, Pfaff T, Udupa S, Hüttel B, Sharma P, Sahi S, Arreguin-Espinoza R, Weigand F, Muehlbauer F, Kahl G, 1999. Characterization and mapping of sequence-tagged microsatellite sites in the chickpea (*Cicer arietinum* L.) genome. *Mol Gen Genet* 262, 90-101.

Yagi M, Yamamoto T, Isobe S, Hirakawa H, Tabata S, Tanase K, Yamaguchi H, Onozaki T. 2013. Construction of a reference genetic linkage map for carnation (*Dianthus caryophyllus* L.). *BMC Genomics* 14, 1-10.

Yan Z, Denneboom C, Hattendorf A, Dolstra O, Debener T, Stam P, Visser P. 2005. Construction of an integrated map of rose with AFLP, SSR, PK, RGA, RFLP, SCAR and morphological markers. *Theoretical and Applied Genetics* 110, 766-777.

Yu C, Jin M, Zhang B, Ming J, Yuan S, Wang Z, Chu L, Liu C. 2012. Genetic linkage map of *Anthurium andraeanum* based on SRAP molecular markers. *Acta Horticulturae Sinica* 39, 1151-1158.

Yuan S, Ge L, Liu C, Ming J. 2013. The development of EST-SSR markers in *Lilium regale* and their cross-amplification in related species. *Euphytica* 189, 393-419.



Supplementary files

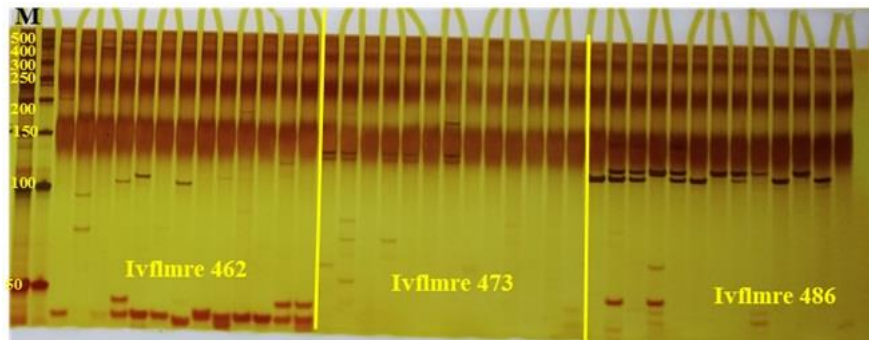

Fig. S1. PAGE of SSR primers ivflmre 462, 473 and 486.

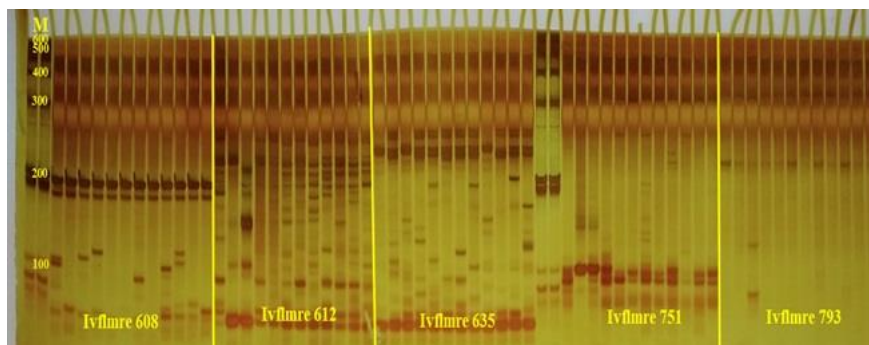

Fig. S2. PAGE of SSR primers ivflmre 608, 612, 635, 751 and 793.

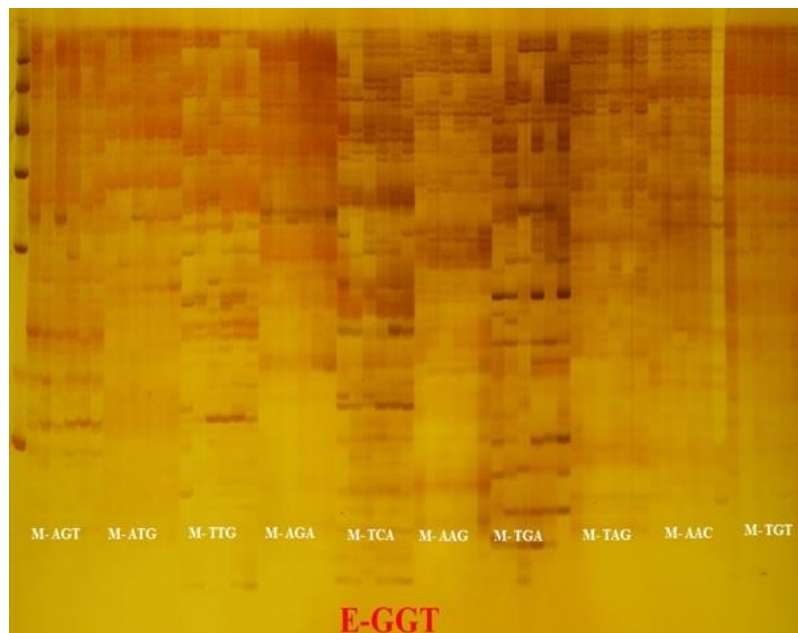
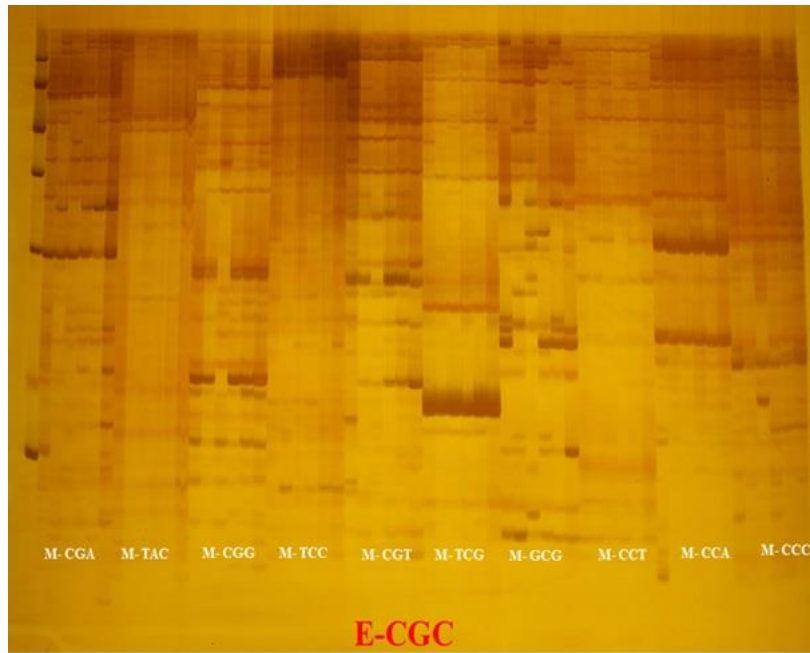

Fig. S3. Different primer combinations of E-GGT with *MseI*.



**Fig. S4.** Different primer combinations of E-CGC with *MseI*.